

ECLIPSE INFORMATION GUIDE

AIR HEAT BURNERS FOR MAKE-UP AIR

Series AH-MA

U.S. Reissue Pat. No. 26,244
Canadian Pat. No. 743,782

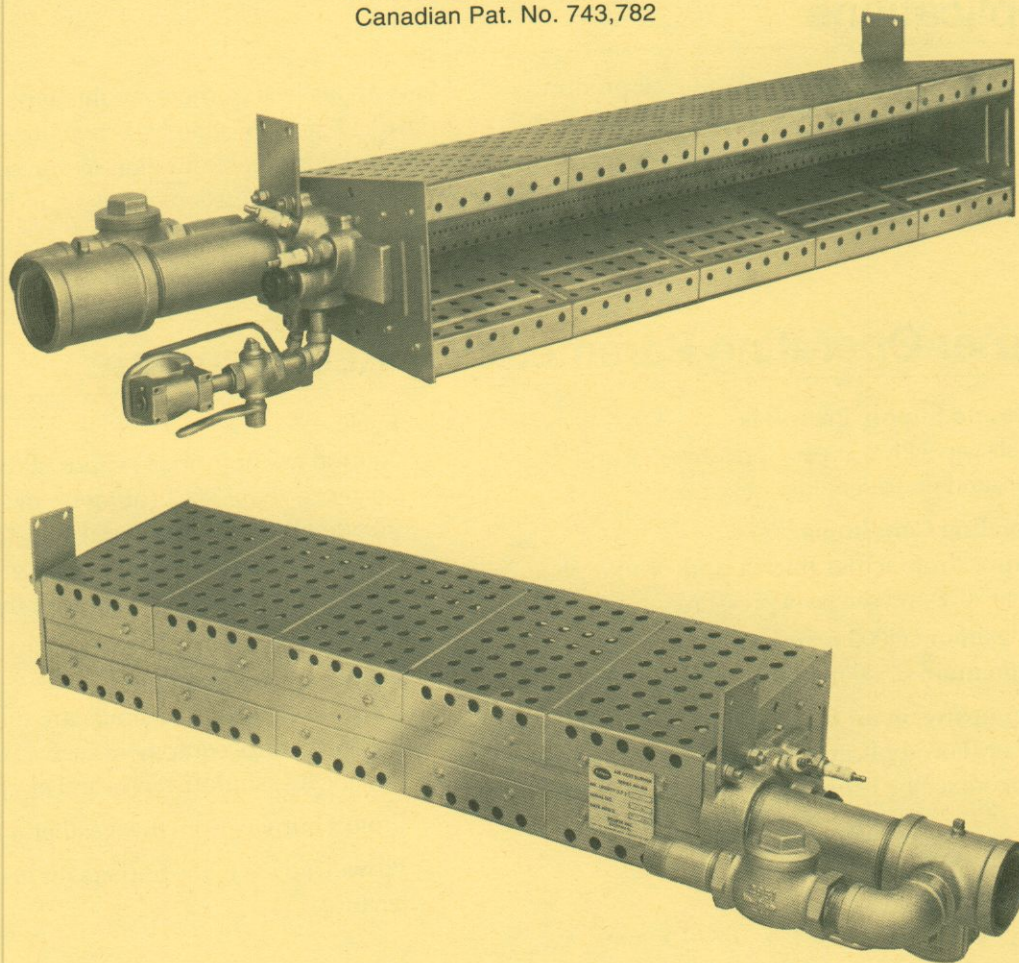

WARNING

The burners covered in this Guide are designed to mix fuel with air and burn the resulting mixture. All fuel burning devices are capable of producing violent explosions and fires when improperly applied, installed, adjusted, controlled, or maintained. This Guide will provide information for using these burners for their limited design purpose. Do not deviate from any instructions or appli-

cation limits in this Guide without written advice from the Engineering Department at the Eclipse Combustion Division in Rockford, Illinois. Read this entire Guide before attempting to light burners. If you do not understand any part of the information in this Guide, contact your local Eclipse representative or the Eclipse Combustion Engineering Department before proceeding further.



ECLIPSE COMBUSTION

Important Notices About Safe Burner Operation

- 1) Store the burner inside. Exposure to the elements can damage the burner.
- 2) Adjustment, maintenance, and troubleshooting of the mechanical parts of this unit should be done by people with good mechanical aptitude and experience with combustion equipment.
- 3) Order replacement parts from Eclipse Combustion only. Any customer-supplied valves or switches should carry UL, FM, CSA, and/or CGA approval where applicable.
- 4) The best safety precaution is an alert and competent operator. New operators must be thoroughly instructed and demonstrate an adequate understanding of the equipment and its operation. Regular retraining must be scheduled to maintain a high degree of proficiency. The operator must have access to this Information Guide at all times.

1.0 Applications

Eclipse AH-MA air heat burners for make-up air produce an odorless, smokeless flame suitable for directly heating fresh air for ventilation purposes. These burners burn natural gas or propane vapor. Burner input is normally controlled by a single control valve in the gas line, allowing turndowns as high as 30:1.

Make-up air heat burners are line type burners assembled from 6", 12" and 18" straight sections, tees and crosses to produce nearly any configuration required. Large burners can be built as a combination of staged, individually controlled sections to increase turndown.

2.0 Burner Operating Parameters & Requirements

2.1 Capacities and Supply Pressures

Table 1 lists capacities, supply pressures, a and pressure drops, and flame lengths.

2.2 Duct Operating Conditions

Air pressure drop across burner and profile plates, corrected to 70°F and sea level pressure:

1.0" w.c. maximum (4000 ft./min. across burner)

0.4" w.c. minimum (2500 ft./min. across burner).

Maximum upstream air temperature: 450°F for standard burner. For applications with higher inlet temperatures, contact the Eclipse factory.

2.3 Fuels

Natural gas or propane vapor. Propane must contain no more than 5% propylene or other unsaturates (Grade HD-5 or equivalent). See Table 1 for gas pressure requirements at the main gas connection. Maximum gas pressure at the inlet of the pilot regulator is 1/2 psig.

2.4 Burner Environment

Ambient temperature limits are dictated by monitoring and control equipment such as flame scanners, automatic fuel shutoff valves and electrical wiring.

Protect burners from the weather.

Provide access to the burners for inspection and maintenance.

Table 1—Capacities & Supply Pressures

Air ΔP Across Burner, ("w.c.)	Air Flow* Per Sq. In. Opening, (SCFH)	Input Per Lineal Foot of Burner (Btu/hr.)		Gas ΔP ("w.c.**)		Flame Length (Inches)
		Maximum	Minimum	Nat. Gas	Propane	
0.4 (min.)	13.6	550,000	25,000	1.2	0.5	18-24
1.0 (max.)	21.5	800,000	26,000	2.5	1.0	24-30

3.0 Control System Requirements

AH-MA make-up air burners are most commonly operated with fixed combustion air flow from a push-through or pull-through fan, but the air volume can be modulated provided the drop across the burner does not go outside the limits specified in Table 1. Operating between these limits will permit an air flow turndown of approximately 1.6:1.

Gas flow is controlled by a single valve in the gas line to the burner. This will permit gas flow turndowns up to 30:1.

If higher turndown is required, AH-MA burners can be staged. This can be done by installing two or more separate burners in a duct, each with its own gas control valve, or by dividing a single burner assembly into separate zoned sections. For example, to triple the effective turndown, three burner sections may be "staged" as shown in Figure 1. Section 1 is used for ignition and low fire heat. If more heat is required, sections 2 and 3 are lit by simply supplying gas to them. They will pilot from the center section. **Lockouts must be provided to shut off gas flow to sections 2 and 3 unless flame is proven on burner 1.** A spacer, #15097, must be installed between sections.

Burner performance is enhanced if the gas inlets to sections 2 and 3 are as close to the piloting section as possible. The gas line to sections 2 and 3 must be equipped with a separate check valve. See H-115 Design, attached, for check valve selection.

3.1 Piloting

AH-MA burners have an integral spark-ignited gas pilot used to light the burner at low fire. The pilot end plate incorporates a pilot gas governor and adjustable pilot gas cock. Gas and air for the pilot are mixed inside the pilot casting without the aid of a separate air/gas mixer. Gas is fed to the pilot at approximately 3.5" w.c. Air is taken from the main air manifold through an integral air orifice. Under normal conditions the pilot will burn approximately 15,000 Btu/hr, but it will operate equally well at higher inputs.

3.2 Flame Monitoring

Flame monitoring can be performed by flame rods or UV scanners. Any flame sensing equipment supplied by the customer should be UL, FM and/or CSA approved. **CAUTION: Failure to use suitable flame sensing devices and automatic fuel shut off valves can cause explosions and fires.**

3.3 Main Gas Valve Train

Gas must be supplied to the burner inlet through a valve train which complies with NFPA Standards and all applicable local codes. Eclipse offers FM and IRI type main gas valve trains as options for AH-MA burners. Each can be ordered with or without a gas regulator. See Bulletin M-700. IRI type trains meet or exceed NFPA Standards.

3.4 Limit Controls

Limit controls and safety equipment should comply with current NFPA Standard 86 and all applicable local codes and/or standards. NFPA Standards are available from:

National Fire Protection Association
Batterymarch Park
Quincy, Massachusetts 02269

IMPORTANT: The owner/user and/or his insurance underwriter must assume responsibility for the acceptance, use, and proper maintenance of the limit controls and other safety devices included with this burner, the flame supervision devices provided in the control panel, and the interfacing of all electrical equipment and sequencing of burner operation between the control panel and the burner.

Figure 1—Staged Burners

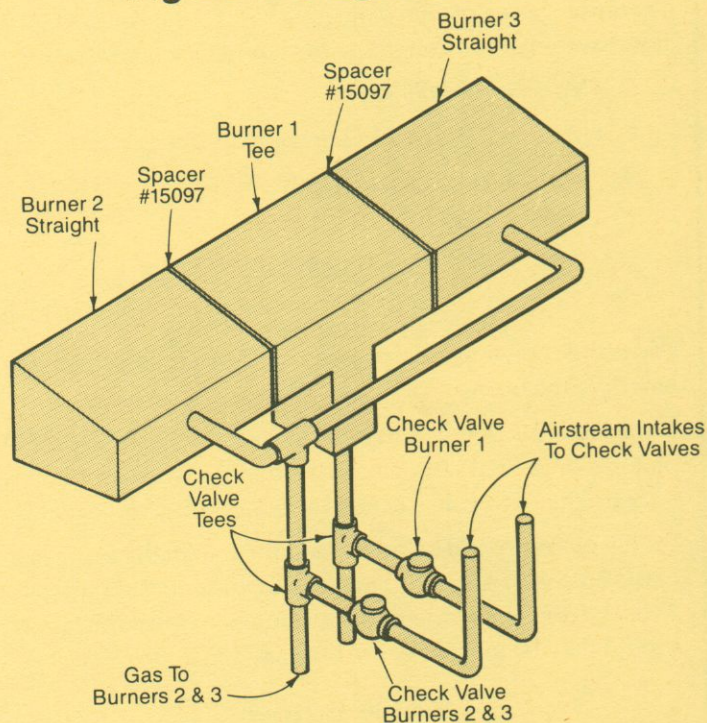

Burner 1 has a Piloting End Plate with pilot, flame rod, and gas inlet/check valve assembly. The spacers separate gas manifolds of the adjacent burners, but allow flame to travel from Burner 1 for ignition of Burners 2 & 3. The check valves must be installed in a horizontal piping run.

WARNING

Do not install any valve or controlling device in the gas line between the burner and the check valve tee, Figure 1. Because this section of the gas line carries a partial premix at low fire, the flame can propagate back through the pipe to the tee. Valves or devices installed in the section can melt, releasing gas to the atmosphere and causing fires or explosions.

Figure 2—Profile Plate Design

Profile Plate Sizing

To calculate the open area between the burner perimeter and the edge of the profile plate opening, solve the following equation:

where
$$A_G = \frac{SCFM_T}{SCFM_R} - (A_{NF} \times L_F)$$

A_G = Area in sq. in. of the gap between the profileplate and the burner.

$SCFM_T$ = Total air flow around and through the burner.

$SCFM_R$ = Air flow required per square inch of open area to produce the specified pressure drop.

A_{NF} = Burner net free area, 11.85 sq. in. per lineal foot of burner.

L_F = Burner length in feet.

Example - Size a profile plate for a 7 foot long AH-MA. Air flow around and through the burner will be 60,000 scfm.

$SCFM_T = 60,000$ SCFM

$SCFM_R = 21.5$ SCFM per sq. in. (from Table 1)

$A_{NF} = 11.85$ sq. in. per ft.

$L_F = 7$ ft.

$A_G = \frac{60,000}{21.5} - (11.85 \times 7) = 2708$ sq. in.

The profile opening must provide uniform air flow down the length of the burner.

If the exact air flow is in doubt, provide adjustable profile plates so that final settings can be made in the field. Shown is one suggested construction for adjustable profile plates.

Profile plates should be positioned flush with the firing end of the burner. If necessary the plates can be located up to 1/2" back from the firing end, but **under no circumstances** should they be in front of the burner.

Single Burner

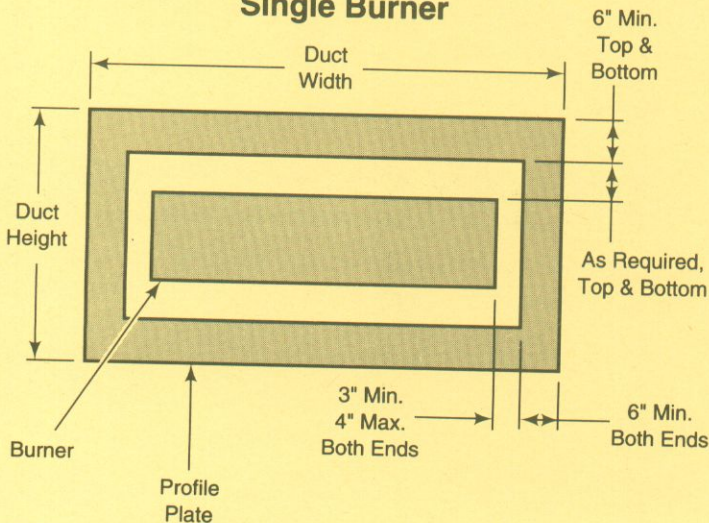

Two Stage Burner

Two-stage makeup air burners employing two separate, parallel burners should have a profile plate between the burners. The gaps between this plate and each burner should equal the gaps between the burners and the outer profile plates (see Figure 3). The width of the profile plate between the burners should be at least 3".

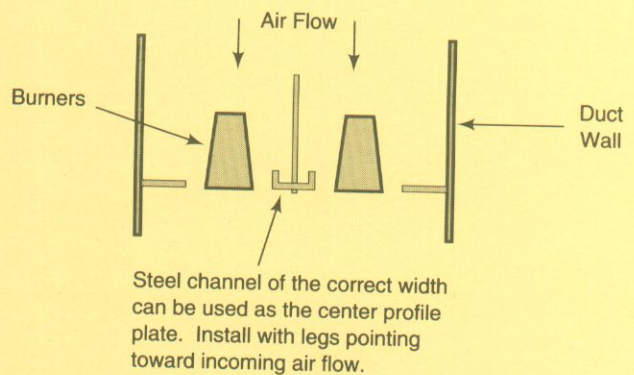
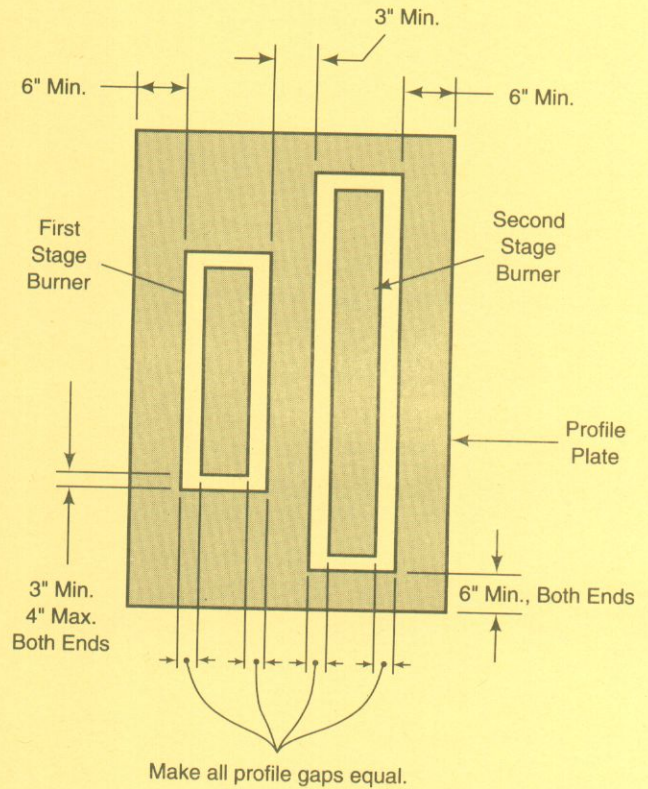
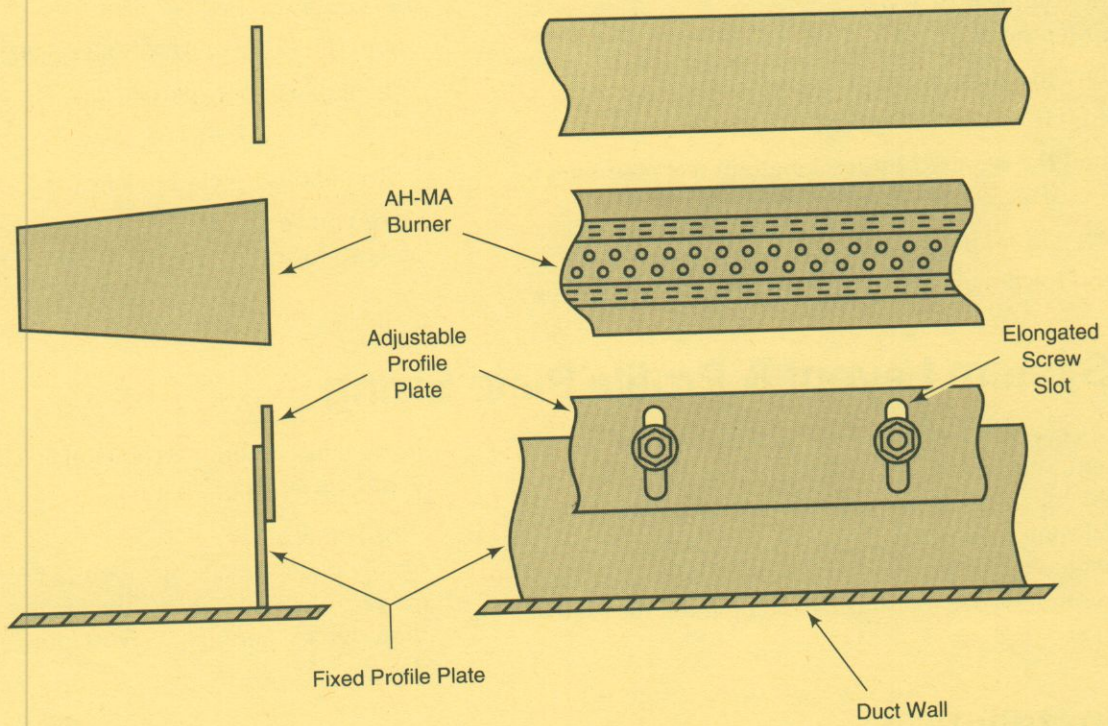
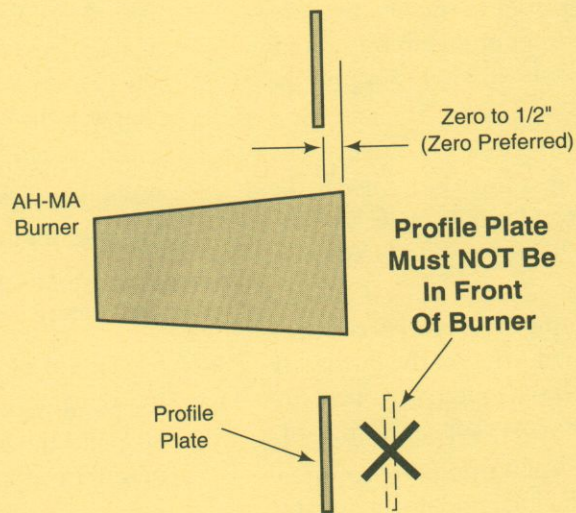

Figure 2 (Continued)—Profile Plate Design

Adjustable Profile Plate



Profile Plate Positioning



4.0 Burner Selection

4.1 Sample Calculation

To select a burner, you will need to know:

Air volume in SCFM.

Air temperature rise (ΔT) in °F.

To find the high fire input required, solve:

$$\text{Btu/Hr.} = 1.1 \times \text{SCFM} \times \Delta T$$

To find the required burner length in feet assuming a 1" w.c. ΔP across the burner, solve:

$$\text{Feet} = \text{Btu/Hr.} \div 800,000$$

Round fractional lengths upward to the next half foot.

Example - A make-up air heat burner will be used to heat 60,000 SCFM air from 0°F. to 80°F. Air ΔP across the burner will be 1" w.c.

$$\text{Btu/Hr.} = 1.1 \times 60,000 \times 80 = 5,280,000 \text{ Btu/Hr.}$$

$$\begin{aligned} \text{Length, Feet} &= 5,280,000 \text{ Btu/Hr.} \div 800,000 \\ &= 6.6 \text{ Feet} \end{aligned}$$

Round this upward to 7 feet.

Once you've determined the required burner length, proceed to Section 5 to lay out the components.

5.0 System Layout & Profile Plate Sizing

5.1 To select components and lay out a system, use H-115 Design, attached, which includes system requirements, schematic symbols, a sketch sheet, and a sample system. Prompt, accurate filling of orders will be aided if you submit this form with your order. Ask your Eclipse representative for assistance in completing the sketch and list.

If you'd like additional copies of H-115 Design, contact your Eclipse representative.

5.2 Profile Plate

Profile plates are always required to insure sufficient air pressure drop across the burner and to promote thorough gas-air mixing. See Figure 2 for profile plate design.

6.0 Installation

6.1 See H-115 Design, attached, for recommendations on the number and placement of gas inlets, as well as other system requirements.

6.2 Use flexible nipples on all gas connections. Solid piping may restrain the burner from normal thermal expansion and damage the burner or its piping components. Do not use the burner assembly to support the piping.

6.3 Check Valve

The check valve airstream intake must be located in the duct upstream of the burner and profile plate. Usually, no additional piping needs to be connected to the airstream intake.

If the order did not specify otherwise, the check valve will be oriented for horizontal firing of the burner. If the burner orientation is to be changed to vertical firing, turn the check valve so its cover cap faces upward.

6.4 If the gas pressure is in excess of the pressure required at the burner, a pressure reducing regulator should be installed. This regulator should be backloaded by means of an impulse line transmitting pressure from the main air duct just forward of the burner to the top diaphragm case of the regulator. This will compensate for the pressure, or suction, condition within the duct and will result in a constant gas pressure to the gas control valve.

6.5 An impulse line should also be run from the duct to the pilot gas regulator.

6.6 Duct Configuration (see Figure 3)

If the burner is operated at the rated input, allow a minimum of 46" from the burner face to the nearest point of flame impingement. This distance is especially important to maintain on a pull-through system with a fan.

If a reducing duct transition is used downstream of the burner, then the following distance should be used between the burner and the transition:

For rectangular ducts: the width or height of one duct section (whichever is greater)

For round ducts: the diameter of one duct section

Either distance will equalize the air flow throughout the duct before it enters the transition piece.

6.7 See Figure 2 for profile plate mounting requirements.

6.8 Suspending the Burner

Suspend the burner from two points only. This will permit freedom for thermal expansion.

Burners up to 4 feet long can be suspended from the end plates. Burners ordered for horizontal firing are furnished with one mounting bracket on each end, as shown in Figure 4a. Burners for vertical firing have two brackets on each end (Figure 4b). Make sure that the hanger rods attached to these brackets clear the check valve and its piping.

Burners greater than 4 feet long should be suspended from two points, each 1/4 of the total burner length from the ends. See Figure 4c. Fabricate brackets which can be firmly attached to the sheet metal diffuser plates

Figure 3—Minimum Duct Lengths

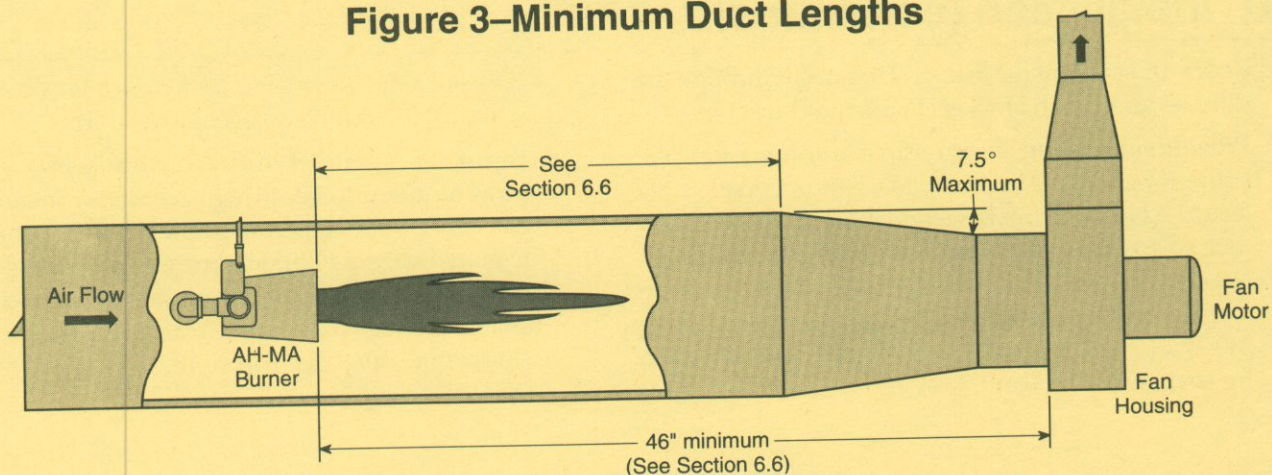

Figure 4—Burner Mounting

All suspension hardware MUST clear the check valve and its piping.

Figure 4a—Burners Up To Four Feet Long, Horizontal Firing

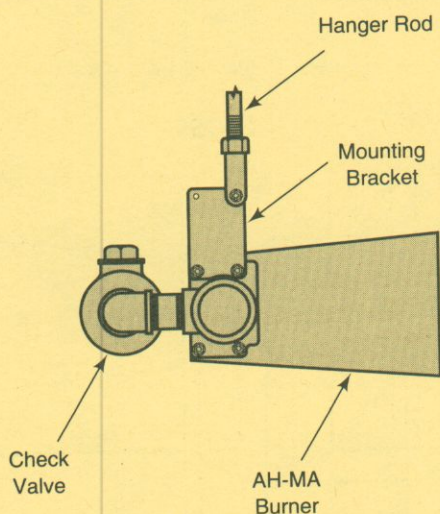

Figure 4b—Burners Up To Four Feet Long, Vertical Firing

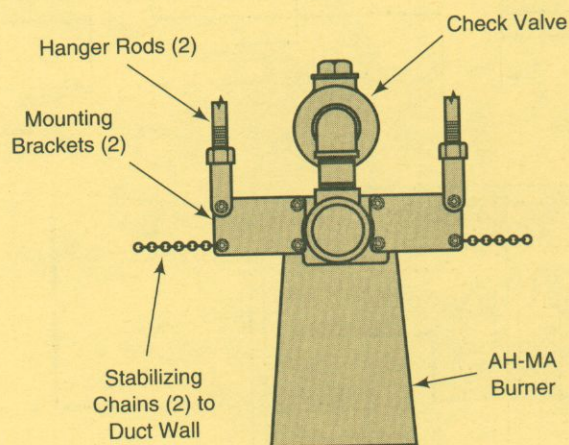
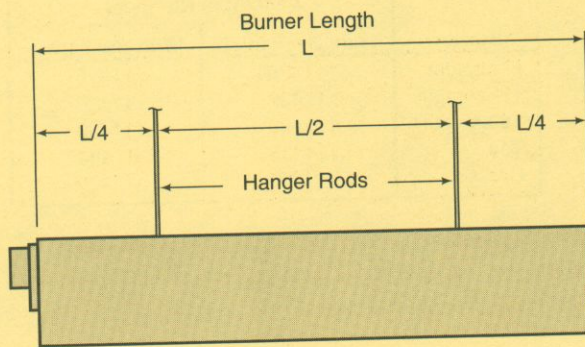

Figure 4c—Burners Over Four Feet Long



6.0 Installation (continued)

on the back and sides of the burner. **Do not** cut through the diffuser and attach brackets to manifold castings.

Provide suspension hangers capable of supporting the entire weight of the burner with a 50% overload safety factor. AH-MA Burners weigh about 20 lb per lineal foot, so a 12 foot long burner, for example, will weigh about $12 \times 20 = 240$ lbs. Each of the two suspension hangers for this burner must be capable of supporting $240 \div 2 \times 1.5 = 180$ lbs. **Solid steel rods are recommended for suspension hangers.** Provide a threaded section at

the upper end of each rod for length adjustment. This will simplify the job of leveling the burner.

Burners suspended to fire vertically may actually sway from side to side in high velocity air streams. This can cause poor centering in the profile opening and eventual fatigue failure of burner and piping components. To keep the burner properly centered, attach chains between the burner suspension points and the sides of the duct. See Figure 4b.

Figure 5—Dimensions

STRAIGHT BURNERS LESS END PLATES

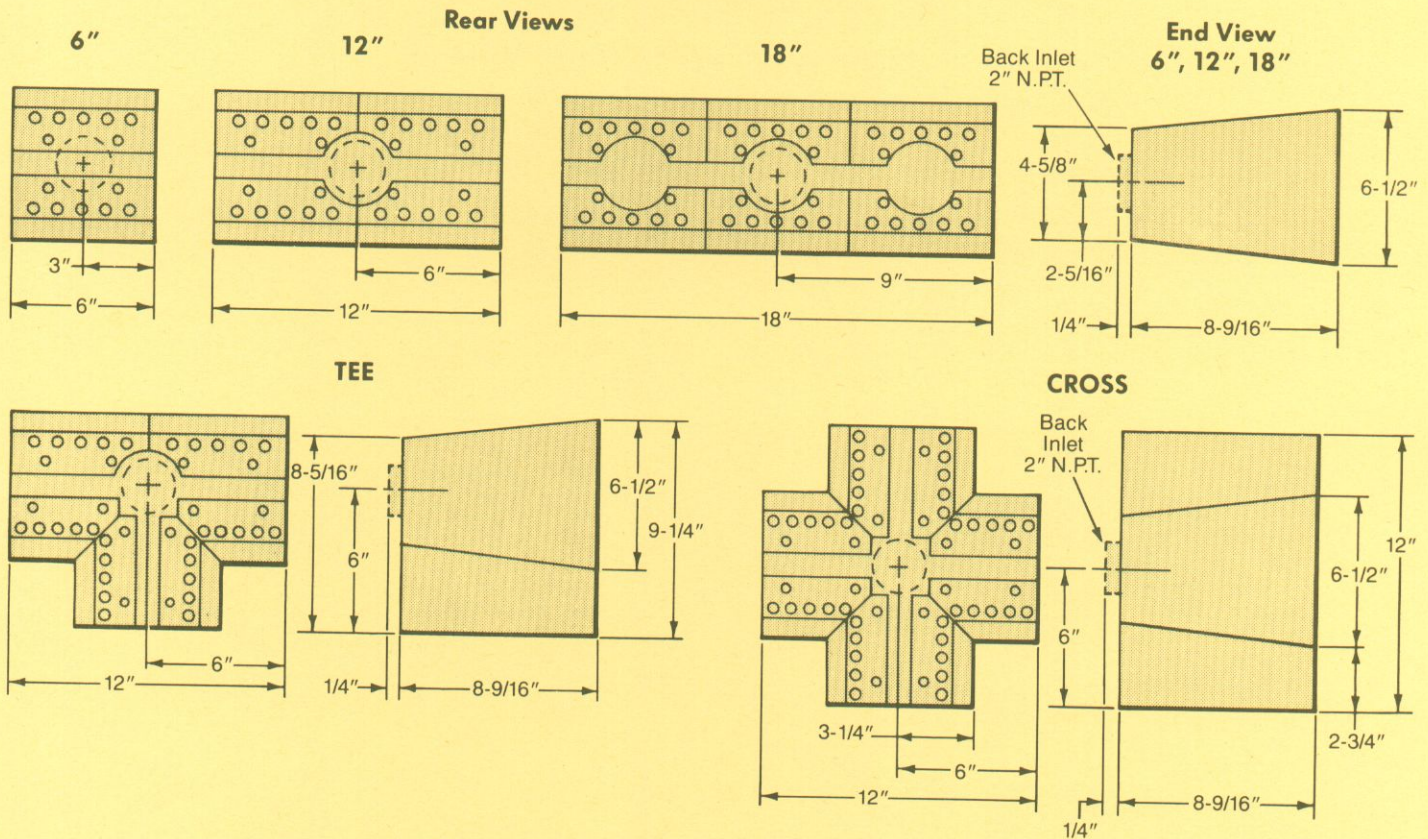

Burner	Assembly Numbers	
	Less Back Inlet	With Back Inlet
6" straight	111425	111426
12" straight	111427	111428
18" straight	111429	111430
Tee	111433	111434
Cross	111431	111432

Figure 5 (Continued)—Dimensions

PILOTING END PLATE

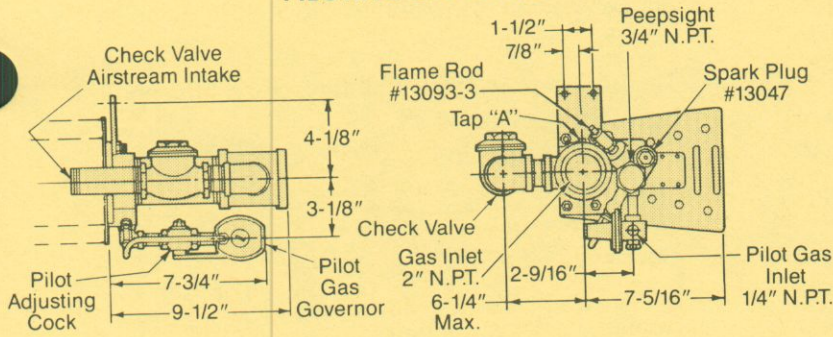

FLAME MONITORING END PLATE #111440

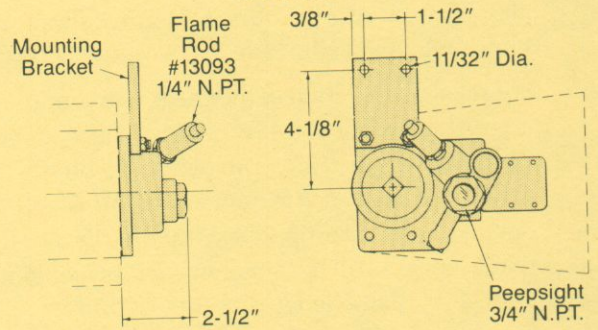

For U.V. scanning, adaptor #109000 is for burners up to 5 feet; it replaces the peepsight (3/4" N.P.T.). Adaptor #109559 is for burners longer than 5 feet; it replaces the flame rod (1/4" N.P.T.).

Lineal Feet of Burner	Pilot End Assembly* Numbers		Check Valves (Included)	
	w/Peepsight & Flame Rod	w/o Peepsight & Flame Rod**	" N.P.T.	Assy. No.
0.5 thru 2.5	111437	111437-1	3/4	550092
3.0 thru 3.5	111436	111436-1	1	550096
4.0 thru 7.5	111439	111439-1	1-1/4	550100
8.0 thru 10.0	111438	111438-1	1-1/2	550104
10.5 thru 18.0	111442	111442-1	2	550108

* Pilot end assembly includes gas inlet casting, ignition plug (#13047), adjustable pilot cock, pilot regulator, check valve, mounting bracket and miscellaneous fittings; when ordered with peepsight, flame rod is #13093-3.

** For use with U.V. scanner.

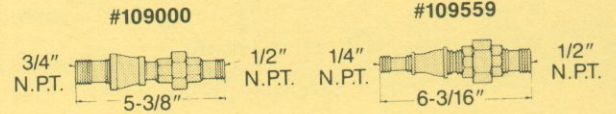

PLAIN END PLATE #111435

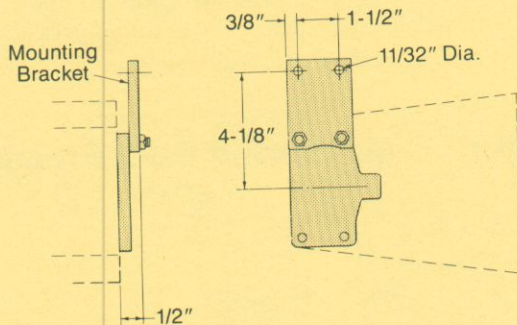

END PLATE FOR GAS FEED ONLY #111443

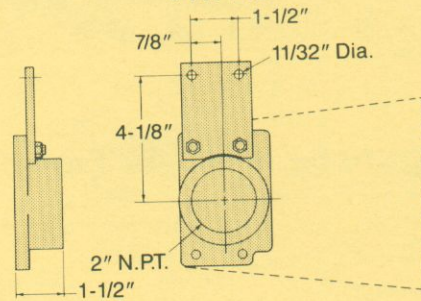

MOUNTING BRACKET #10023

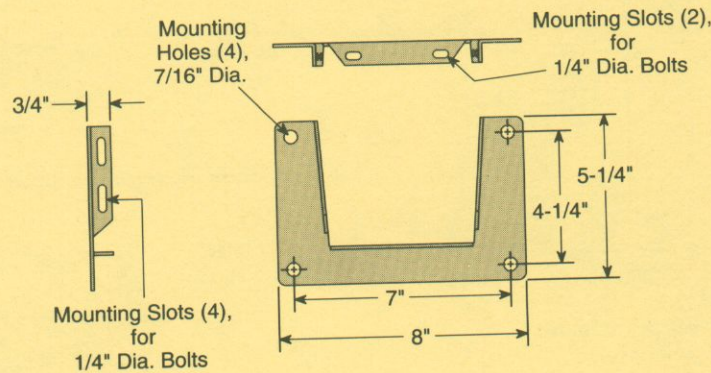

7.0 Start-Up

7.1 Start the main fan on the makeup air unit. Set the fan inlet damper to produce the desired pressure drop or air velocity across the burner. Figure 6 shows the relationship between the two.

For reliable operation of the check valve, minimum ΔP across the burner is 0.4" w.c. This will produce an 18-24" flame length at an input of 550,000 Btu/hr. per lineal foot of burner. Air flow at this ΔP is sufficient to operate the burner up to 800,000 Btu/hr. per foot, but flame lengths will become considerably longer. To obtain 24-30" flame lengths at 800,000 Btu/hr. per foot, increase the ΔP to 1.0" w.c.

- 7.2 Air velocity can be read directly with an anemometer or velometer. Pressure drop can be read as a differential pressure across the burner, using a U-tube manometer, or as velocity pressure, using a pitot tube and draft gauge, as shown in Figure 7.
- 7.3 Air velocity or differential pressure must be uniform at all points around the profile opening in order to insure uniform temperature distribution. If it isn't, adjust the gap between the profile plate and the burner.
- 7.4 New gas lines will be full of air and should be purged before trying to light the burner.
- 7.5 With the makeup air fan operating, energize the ignition transformer and open the pilot gas cock for lighting the pilot. The pilot flame, which can be observed from the front of the burner or through the peepsight,

will be a bushy, blue flame. This should provide a stable pilot with good microamp readings sufficient to energize the main gas valve.

- 7.6 The pilot is pre-adjusted at the factory, but should it have to be re-adjusted, remove the cap and turn the adjusting screw clockwise for less gas and counter-clockwise for more gas; see the cross sectioned illustration at right.

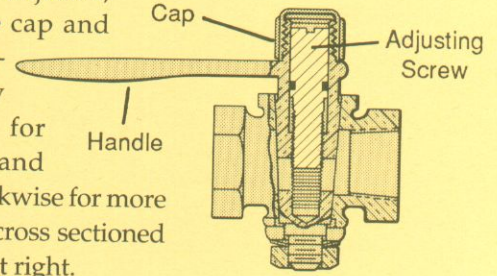

For flame rod systems, the proper amount of pilot gas is the minimum that will reliably ignite each time the spark electrode is energized. Excess gas will not adversely affect the pilot operation, but should be held to a minimum since the pilot gas flow is added to low fire, thus restricting turndown.

A U.V. scanner system will require a slightly larger pilot than a flame rod system to develop sufficient microamp signal.

- 7.7 Use a manometer to check the gas pressure to the main burner at the tap shown in Figure 8.

Gas pressures at the burner must equal the maximum duct pressure plus the differential pressure required to give the desired capacity. The required pressure differentials for various inputs are listed in Figure 8.

Figure 6— ΔP VS Air Flow

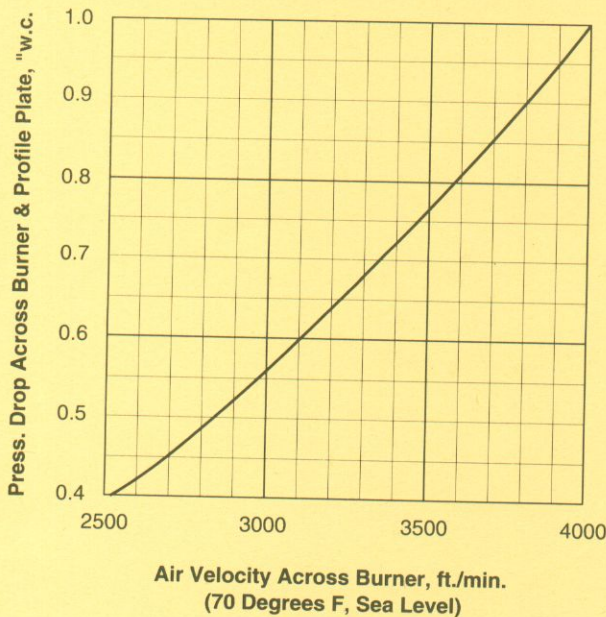

Figure 7—Measuring Duct Pressure

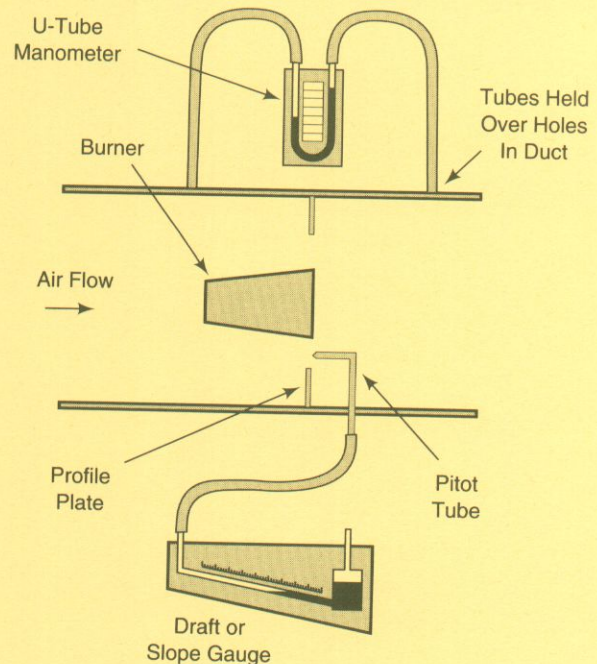
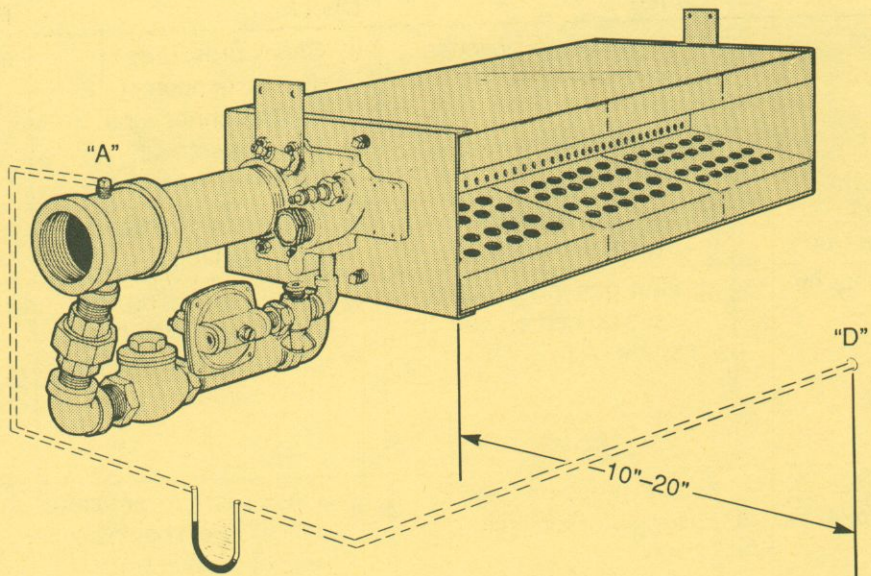

Figure 8—Measuring Gas Differential Pressure



**Differential Pressures Between "A" & "D"
For Various Inputs**

Fuel	Btu/hr. Per Foot of Burner, in 1000's					
	550	600	650	700	750	800
Natural Gas	1.2	1.4	1.65	1.9	2.2	2.5
Propane	0.5	0.6	0.7	0.8	0.9	1.0

8.0 Trouble-Shooting

Symptom	Cause	Check	Remedy
1. Burner does not start initially.	<ul style="list-style-type: none"> a) Air pressure switches not making. b) Faulty pressure switches. 	<ul style="list-style-type: none"> a) Check pressures in duct at location of switch connections. b) Check electrical portion of switch. 	<ul style="list-style-type: none"> a) Change pressure connections where a more positive pressure is present.
2. Burner kicks out shortly after start-up.	<ul style="list-style-type: none"> a) Low gas pressure switch set too high. 	<ul style="list-style-type: none"> a) Check low pressure switch setting. 	<ul style="list-style-type: none"> a) Reset
3. Pilot will not ignite on initial light-off.	<ul style="list-style-type: none"> a) Raw gas fed into pilot causing carbon hair on spark plug. 	<ul style="list-style-type: none"> a) Check spark plug for carbon hair; also check gap on plug (should be 3/64" - 3/32"). 	<ul style="list-style-type: none"> a) Adjust pilot gas cock by first screwing needle closed, then with transformer powered, open needle slowly 1/4 turn at a time.
4. Flame failure when burner goes to high fire.	<ul style="list-style-type: none"> a) Gas pressure to pilot regulator too high. b) Bolts which fasten pilot casting to burner are not tight enough. c) Pilot regulator not reacting fast enough to duct pressure changes. d) Check valve stuck open. e) Too much pilot gas. 	<ul style="list-style-type: none"> a) Check pilot gas pressure to regulator (should be 1 PSIG maximum). b) Check tightness of bolts. c) Check impulse line for possible dirt clogging; also check impulse line duct connection to determine if an effective pressure is being transmitted to regulator. 	<ul style="list-style-type: none"> a) Relocate pilot gas line or use second pilot regulator. b) Tighten bolts. c) Clean impulse line of any dirt particles and relocate duct connection to transmit maximum duct pressure. d) Clean check valve. e) Reduce pilot gas flow.
5. Flame failure when main burner returns from high to low fire.	<ul style="list-style-type: none"> a) Gas pressure to pilot regulator. b) Under-gassing pilot. 	<ul style="list-style-type: none"> a) See Check 4a. b) Check pilot regulator inlet and outlet gas pressures; also check pilot flame. c) See Check 4c. 	<ul style="list-style-type: none"> a) See Remedy 4a. b) Open needle on pilot adjusting cock slowly 1/4 turn at a time. c) See Remedy 4c.
6. Main flame too large at high fire.	<ul style="list-style-type: none"> a) Gas pressure too high at burner inlet. b) Combustion air pressure too low. c) Check valve stuck open. 	<ul style="list-style-type: none"> a) Check gas pressures. b) Check air pressure differential. 	<ul style="list-style-type: none"> a) Screw out on main gas pressure regulator. Adjust linkage on gas control valve to hold valve less than full open when at high fire. b) Open air shutter on makeup air blower. c) Clean check valve.
7. Main flame not extending beyond face of burner at high fire.	<ul style="list-style-type: none"> a) Air pressure differential too high. b) Burner not firing rated input. c) Burner gas holes plugged. 	<ul style="list-style-type: none"> a) Check air pressure differential between combustion air manifold and main duct. b) Check gas pressure differential. c) Check gas holes for dirt or lint. 	<ul style="list-style-type: none"> a) Close air shutter on makeup air blower. b) Screw in on main gas pressure regulator to provide more gas. c) Clean gas holes with #42 MTD drill. Clean air holes with #27 MTD drill.
8. Main flame long and yellow.	<ul style="list-style-type: none"> a) Velocity past burner lower than 500 FPM. b) Check valve stuck open. 	<ul style="list-style-type: none"> a) Check velocities and rotation of main circulating fan. 	<ul style="list-style-type: none"> a) Open shutter on makeup air blower. b) Clean check valve.



ECLIPSE COMBUSTION



Offered By:

Power Equipment Company
2011 Williamsburg Road
Richmond, Virginia 23231
Phone (804) 236-3800
Fax (804) 236-3882

www.peconet.com